



VENT SILENCER

PRODUCT GUIDE

PULSCO VENT SILENCER

TABLE OF CONTENTS

<u>DESCRIPTION</u>	<u>PAGE</u>
PULSCO VENT SILENCERS	
GENERAL INFORMATION	4
VENT SILENCER COMPONENTS	5
PULSCO VENT SILENCER MODEL DESCRIPTIONS.....	7
ALTERNATE MATERIALS OF CONSTRUCTION	11
HIGH TEMPERATURE DESIGN.....	11
FLANGES.....	11
SILENCER SUPPORTS.....	11
DESIGN PROCESS	12

GENERAL INFORMATION

Mailing Address: PULSCO, Inc.
17945 Sky Park Circle, Suite G
Irvine, CA 92614

Main Voice: Ph: 949.261.1717
TF: 877.785.7262
Fx: 949.975.0532

Email: sales@pulSCO.com

Web Page: www.pulSCO.com

Office Hours: 07:00-17:00 PST
(Voice Mail after Hours)

PULSCO

VENT SILENCER PRODUCT GUIDE

GENERAL INFORMATION

PULSCO has been designing and manufacturing industrial grade acoustic silencers to meet customers' specific requirements for over 50 years. PULSCO Vent Silencers reduce the noise produced by the expansion of gas or steam from elevated pressures to atmospheric pressure. These absorptive silencers are used to suppress noise generated by high velocity gas streams such as steam vents, safety relief valve outlets, system blow downs and purge outlets. Each vent silencer is designed to attenuate the noise level to the required level criteria at a given distance from the silencer.

The overall size of a vent silencer is directly proportional to the desired noise reduction and the flow rate of the particular gas. Noise reduction depends on the silencer length, while the diameter of the silencer depends on the gas flow rate. The silencer is designed for a maximum velocity to minimize sub-sonic jet noise at the silencer discharge and ensure structural integrity. There are no moving parts in the operation of the vent silencer units. These silencers can range from 12 inches up to 12 feet in diameter.

All PULSCO Vent Silencers are Blowdown Vent Silencers (BVS) and are fitted with a bottom inlet nozzle. Vent Silencers can be easily adapted for special applications that require a side inlet. This can greatly facilitate installation of the silencer by eliminating the need for elbows in the piping system. Each vent silencer is fitted with an inlet nozzle sized to be compatible with the customer's existing or planned piping. All PULSCO vent silencers are quoted on a case by case basis, incorporating customer unique specifications and operating conditions to fully meet customers' form, fit and function requirements. Each silencer is designed and constructed to withstand the thermal and shock stresses produced in high-pressure, high-temperature, continuous or periodic vent operations.

VENT SILENCER COMPONENTS

The three principal components of the PULSCO vent silencer that actively reduce noise are the **Pressurized Inlet Diffuser**, **Plenum Section** and **Acoustic Tube Module** as shown in Figure 1. Each component accomplishes diffusion and smoothing of the flow and an overall reduction of noise.

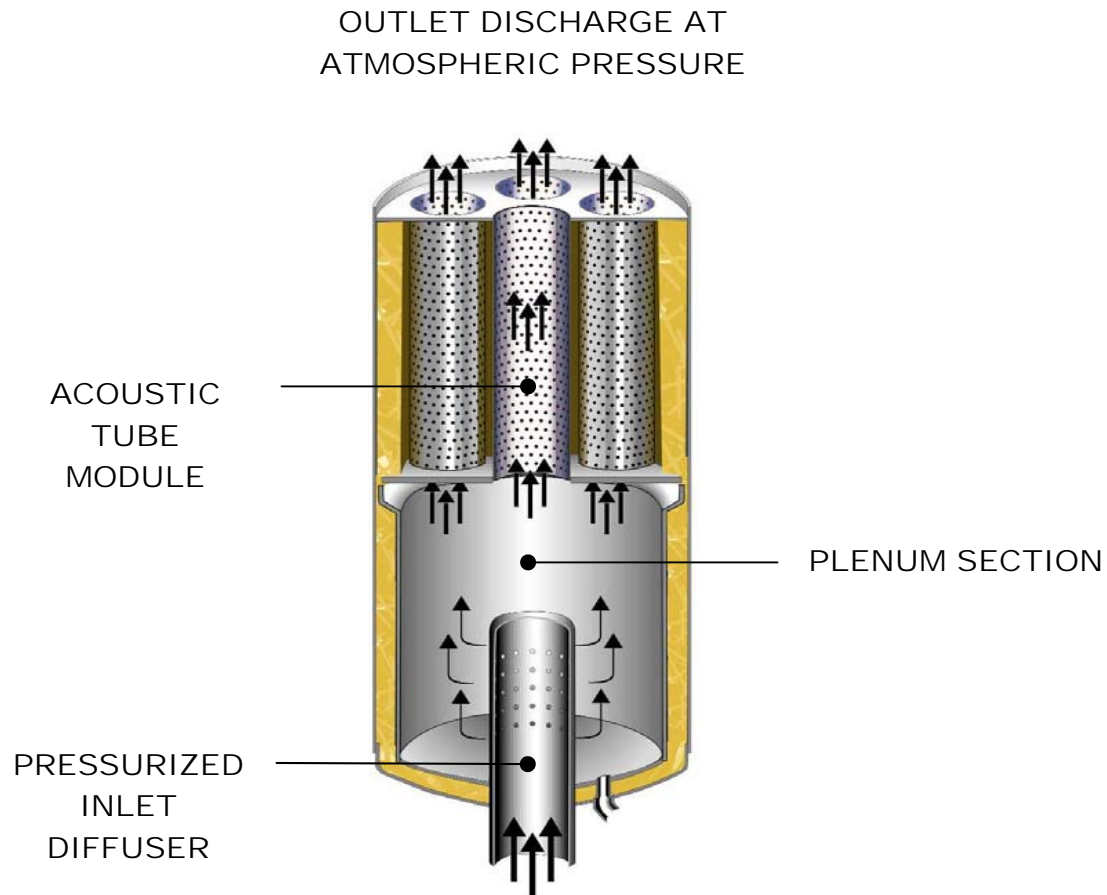

FIGURE 1. VENT SILENCER

The **Pressurized Inlet Diffuser** provides energy dissipation and modification of the noise spectrum for easier attenuation. It does this by breaking up the large jet stream of gas into many small jets. The diffuser also provides backpressure on the valve for optimum performance of the valve. This backpressure reduces the pressure drop across the valve which reduces the noise generated by the valve and reduces the velocity downstream of the valve. While increasing the pressure at the inlet diffuser will not affect the required diameter of the vent silencer, ***it may reduce the size and noise trim requirements of the valve.*** Valve performance and life can be significantly improved by appropriate allocation of the pressure drop between the valve and the vent silencer. ***Providing appropriate backpressure on the valve has very little, if any, impact on the silencer cost, but can significantly reduce the cost of the valve and piping.***

The **Plenum Section** is an expansion chamber and is constructed to smooth and uniformly distribute the flow while reducing sound energy before it enters the Acoustic Tube Module. The Plenum Section is also designed to minimize noise radiation through the shell wall. It also slows the flow velocity prior to entry into the Acoustic Tube Module.

The **Acoustic Tube Module** consists of multiple parallel circular flow tubes surrounded by acoustic packing that absorb and attenuate the acoustic energy entering from the Plenum section. In addition, it is designed and constructed to accommodate the differential thermal expansions that occur in cyclical operations.

Other features of the PULSCO silencers include the following. The PULSCO Vent Silencer is an atmospheric pressure unit. As such, the silencer shell and bottom head are not subjected to pressure loading. The inlet diffuser is the only component that is exposed to elevated operating pressures. The diffuser is sized and configured by PULSCO to produce a specified backpressure on the source. Although the diffuser is designed in accordance with Section VIII, Div 1 of the ASME Code for operating pressure equal to the valve backpressure, it is not a closed vessel and cannot receive an ASME stamp. The operating pressure is directly proportional to the mass flow through the diffuser. It is therefore important that **all** flow cases be examined to establish the maximum operating pressure of the diffuser. Ordinarily, this condition will occur when the valve is fully open.

- The **SHELL AND HEAD** are welded, heavy-duty fabrications constructed of plate steel to give long lasting service and minimize noise transmission.
- **DRAIN COUPLINGS** are provided to prevent liquid build-up in the plenum area.

- A **COMPACT DESIGN** is utilized to minimize the required support structures. A variety of supports can be provided to meet specific field application requirements.
- An **ACOUSTIC DESIGN** is utilized to achieve maximum attenuation of the noise level entering the silencer.
- PULSCO offers **GUARANTEED PERFORMANCE of the silencer** when it is selected with the **PULSCO Vent Silencer Sizing Program**. This program assures that the silencer will meet the specified application conditions for **both flow capacity and silenced noise levels**. The effects of the type of valve, the individual pressure drops across the valve and vent silencer inlet diffuser, the location of the acoustic measurement point and the noise generated by the exhaust stream after leaving the silencer are all included in the program.

PULSCO VENT SILENCER MODEL DESCRIPTIONS

PULSCO Vent Silencers are available in diameters from 12 to 144 inches providing capacities for a wide range of flows. Each size is available in several lengths to provide, depending on the application, acoustic insertion loss up to 50dB. PULSCO uses model designators that specify the nominal shell inside diameter of the unit and the relative acoustic performance represented by a "Dash Model". There are five dash models, namely the **Dash 2** (-2), the lowest acoustic insertion loss, **Dash 3** (-3), **Dash 4** (-4), **Dash 5** (-5) and the **Dash 6** (-6), the highest acoustic insertion loss.

For example, Model BVS 30-4 designates a unit 30 inches in diameter with a "Dash 4" tube module. As seen in Figure 2, the Model BVS 30-4 would have a height of 107 inches and weigh 900 pounds.

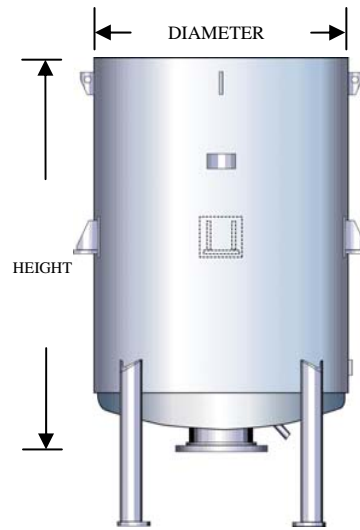

FIGURE 2. VENT SILENCER MODEL DIMENSIONS

Nominal Shell Diameter (inches)	Dash 2		Dash 3		Dash 4		Dash 5		Dash 6	
	Height (inches)	Weight (lbs)	Height (inches)	Weight (lbs)	Height (inches)	Weight (lbs)	Height (inches)	Weight (lbs)	Height (inches)	Weight (lbs)
12	55	140	--	--	79	250	--	--	103	320
18	58	230	--	--	82	420	--	--	106	540
24	65	360	--	--	95	670	--	--	125	870
30	71	520	--	--	107	980	--	--	143	1290
36	84	800	108	1150	132	1500	156	1760	180	2000
42	97	1,120	133	1690	157	2100	193	2560	217	2860
48	110	1,420	146	2140	170	2690	206	3220	230	3580
54	123	1,830	159	2640	195	3480	231	4080	267	4690
60	100	1,900	124	2650	148	3480	172	4040	196	4560
66	125	2,540	161	3790	185	4800	221	5690	245	6310
72	126	3,370	162	4890	186	6360	222	7490	246	8280
78	139	4,150	175	5810	211	7860	247	9130	283	10400
84	140	4,510	176	6310	212	8560	248	9940	284	11320
96	129	5,410	165	7720	189	10040	225	11810	249	13060
102	142	6,130	178	8730	202	11410	238	13310	262	14650
108	155	8,270	191	11,260	227	15550	263	17880	299	20210
120	168	9,810	204	13300	240	18500	276	21120	312	23750
132	194	13,260	242	18080	290	24880	276	28740	386	32710
144	196	15,120	244	20420	292	28040	340	32300	388	36680

The basic components of each vent silencer model are shown in Figure 3 and are described below.

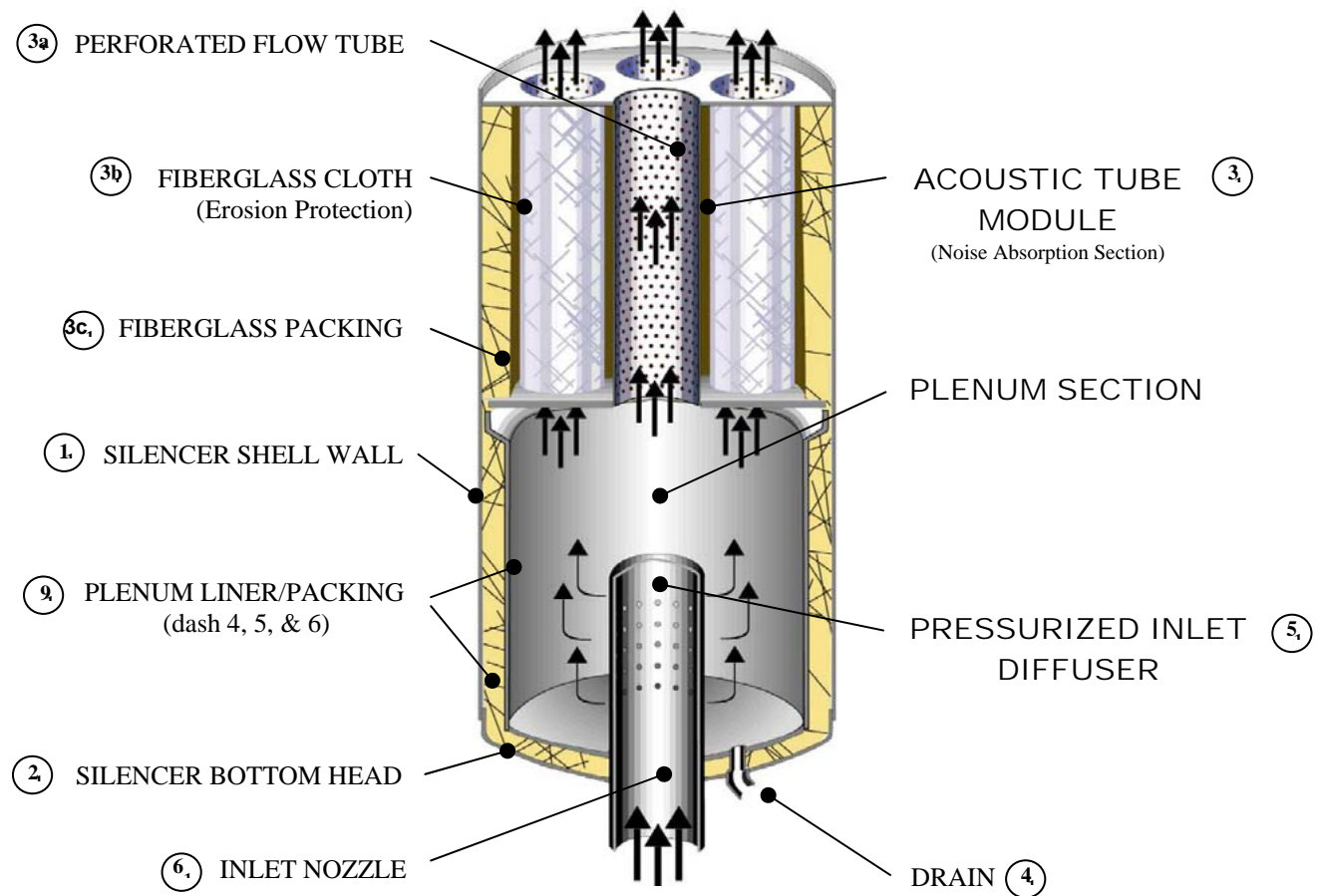

FIGURE 3. VENT SILENCER COMPONENTS

MODELS DASH 2 THROUGH DASH 6

Component Name

- | | |
|---------------------------------|--|
| (1) Silencer Shell Wall: | Rolled and welded plate steel. It is open to the atmosphere at the outlet end. |
| (2) Silencer Bottom Head: | Flanged and dished head. |
| (3) Acoustic Tube Module | The acoustically absorptive section; consists of (3a) perforated 14 Gage steel flow tubes, (3b) fiberglass cloth wrapped around each tube provides erosion protection and (3c) acoustical packing consists of long strand, inert, non-combustible, moisture resistant fiber-glass which has a high acoustic absorption coefficient. |
| (4) Drain Coupling: | 1" or 2" NPT coupling installed in the bottom head. |
| (5) Pressurized Inlet Diffuser: | Integral with the inlet nozzle; sized and configured to produce the proper valve backpressure specified in the application data. |
| (6) Inlet Nozzle: | Beveled-for-weld pipe (or rolled plate) fitted through and attached to the shell bottom head. (Flanges are usually added.) |
| (7) Finish: | High temperature black paint on external surfaces of the shell and bottom head (alternative finishes are available, if required by the customer). |

MODELS DASH 3 ONLY

- | | |
|--------------------|--|
| (8) External Liner | 12 Gage sheet wrapped around the shell (not shown in the sectioned view of Figures 1 or 3). This prevents shell radiation noise from exceeding the noise out of the tube module. |
|--------------------|--|

MODELS DASH 4 THROUGH DASH 6

- | | |
|--------------------------|--|
| (9) Plenum Liner/Packing | Double-wall construction separated by a layer of acoustic insulation. The Plenum liner reduces the shell-radiated noise. |
|--------------------------|--|

MATERIALS OF CONSTRUCTION

Silencer components are generally constructed from carbon steel, however they may be constructed from other materials to meet specific design or application requirements such as high temperature, corrosive environment or oxygen service. Material recommendations are dependent on the specified operating conditions.

For a corrosive environment, components or complete silencers can be constructed from a 300 Series Stainless Steel (usually 304 or 316). For oxygen service, Monel or a Monel/300 series steel combination is usually used together with special cleaning and degreasing procedures.

HIGH TEMPERATURE DESIGN

Construction materials used in vent silencers designed for temperatures in excess of 1,000 °F are determined by the specified operating conditions. At these elevated temperatures, PULSCO establishes the silencer design as a “Special Design”. This requires particular attention on the design of the diffuser and may require all stainless steel construction, special packing and extraordinary erosion protection.

- a) An economical high temperature black paint is available for temperatures up to 1,000 °F.
- b) Other paints such as zinc rich primer can be provided if required by the customer.

FLANGES

ANSI B16.5 flanges are normally quoted. Other type flanges can be quoted on an individual basis.

SILENCER SUPPORTS

While the smaller vent silencers can be self-supporting, vent silencers usually should be ordered with external supports; this is especially true for the larger sizes. PULSCO has standard designs for lugs, legs or saddles that are suitable for high environmental loads (Zone 4 seismic/90 MPH wind). Other supports can be provided to meet specific customer requirements. PULSCO will design skirt/base-ring supports to meet specified loads and mounting requirements. PULSCO will also fabricate and install other designs per the customer drawings; the integrity of such designs is the responsibility of the customer. PULSCO can review the supporting requirements based on service and local environmental loads.

When the silencer is restrained, the loads imposed by the piping on the silencer inlet nozzle must be evaluated. PULSCO will assist the customer in evaluating the silencers ability to withstand the loading conditions.

Silencers that will be installed without additional supports should be evaluated for their ability to withstand the applicable environmental loads when supported only by the inlet nozzle. The adequacy of a nozzle-supported silencer depends on many factors including the magnitude of the loads (installation location and local site conditions), applicable code and/or customer specification, silencer size and materials of construction, operating temperature and nozzle size; thus general guidelines are not feasible. PULSCO will evaluate these factors on a case-by-case basis if provided with the appropriate criteria/data. Note that the smaller silencers (roughly up to Model BVS 36) can be self-supporting except for extreme cases of high loads and/or small nozzles.

Nozzle gussets can be used to increase the range of acceptable loads when the use of other supports is not practicable. However, PULSCO must evaluate these on an individual basis.

DESIGN PROCESS

The PULSCO Vent Silencer Sizing Program incorporates the customer's operating conditions, specifications and system description to select the most cost effective vent silencer configuration.

The following information is required to size a vent silencer (please use the **QF 7.2 - 910 Vent Silencer Application Sheet** and fax or e-mail the information to PULSCO):

1. The Fisher Sizing Report showing the Valve and Diffuser calculations
2. Type of Gas and Specific Gravity or Molecular Weight, if it is not steam
3. Flow Rate
4. Local Atmospheric Pressure
5. Pressure Upstream of the valve
6. Temperature Upstream of the Valve
7. Diffuser Inlet Pressure
8. Ratio of Specific Heats (C_p/C_v)
9. Noise Criteria to be met: dBA at a specified Distance and Angle from the axis of the Silencer (e.g. 90dBA at 10 feet and 90 degrees)

10. Inlet Nozzle Size
11. Connection Type
 - Flanged (size and rating)
 - Butt Weld End (size and schedule or wall thickness)
12. Valve Type
13. Other requirements, such as, orientation (vertical or horizontal), material of construction, special paint, support requirements (legs, lugs, skirts, saddles, etc.), acoustic weather-hood, etc.

IMPORTANT: If the customer requires special construction and/or application standards, PULSCO must have their written requirements before a quotation is finalized. Unless PULSCO is provided copies of all relevant customer specifications, the silencers are manufactured to our standards.

The customer is provided with a drawing that is specific to the application. This drawing specifies:

- Silencer Dimensions
- Application Data and Conditions
- Materials of Construction
- Type of Finish
- Silencer Accessories, if any
- Special customer requirements and designations, if any

FREIGHT & SHIPPING

All orders shipped are F.O.B. factory unless other arrangements have been made. Unit sizes 12” through 36” are shipped on a skid to allow for pick up by fork or sling. Openings are covered and protected. The shipping packet contains a packing list, outline drawing and installation instructions.

Manufacturing lead-time for standard vent silencers up to 42 inches in diameter is 6 to 8 weeks. Large vent silencers and silencers with stainless steel or other special material are 8 to 16 weeks.

PULSCO warrants equipment for workmanship and materials for one year from date of initial operation or eighteen months from date of shipment, which ever is earlier.